

**LIPA 400 AMP TRANS "S"**  
**CURRENT TRANSFORMER CABINET (NEMA 3R)**  
**200 AMP. & 400 AMP., 600V AC RATED**  
**CATALOG NUMBER TS-400-208(1) TS-400-208(3)**  
**RTS-400(1) RTS-400(3)**

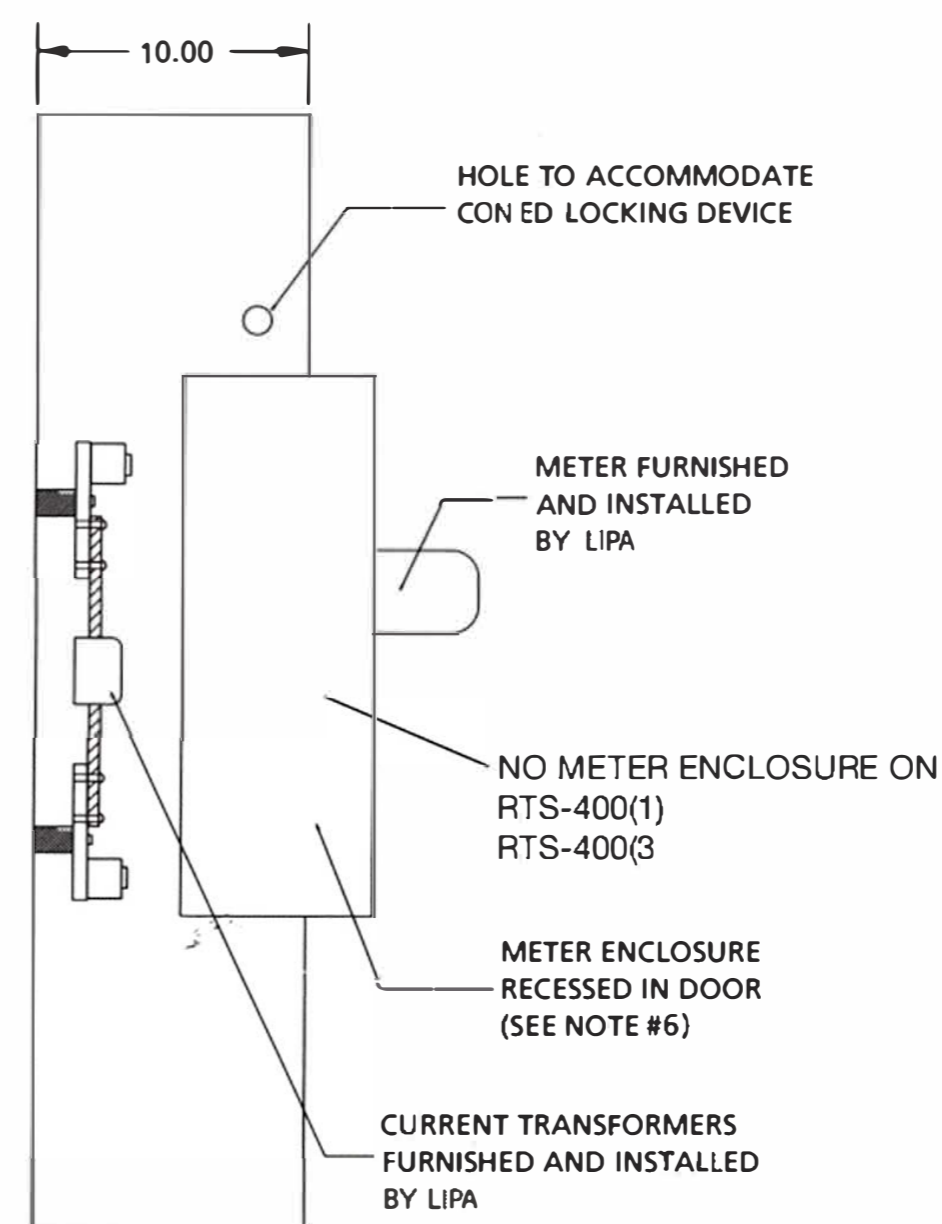

**SIDE VIEW**

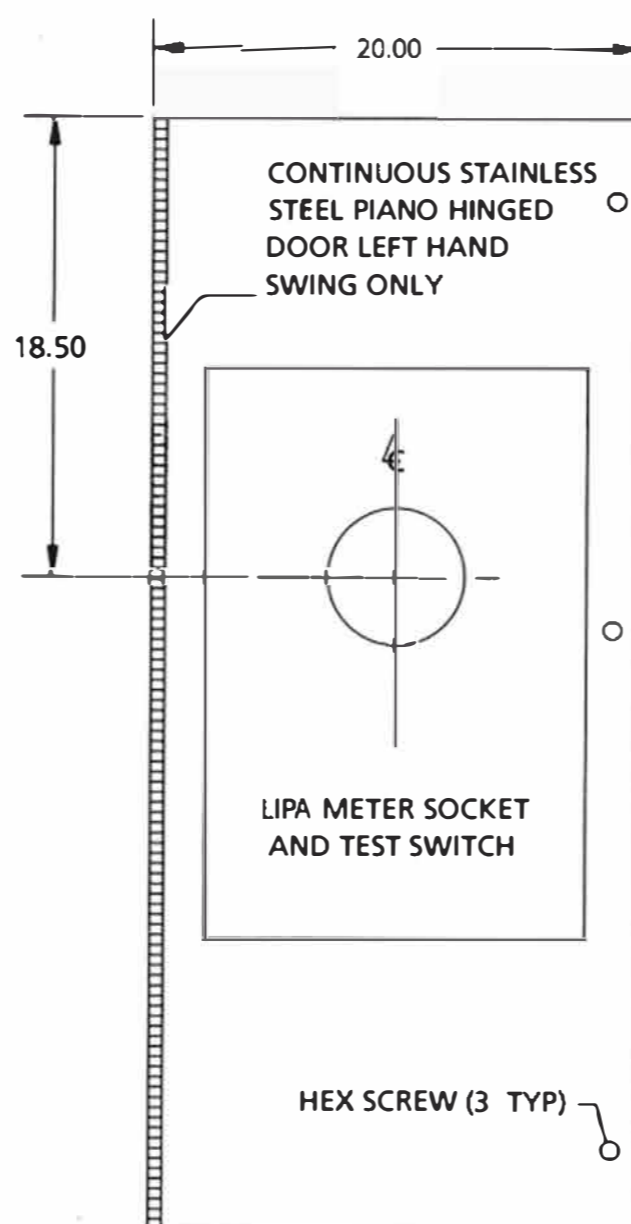
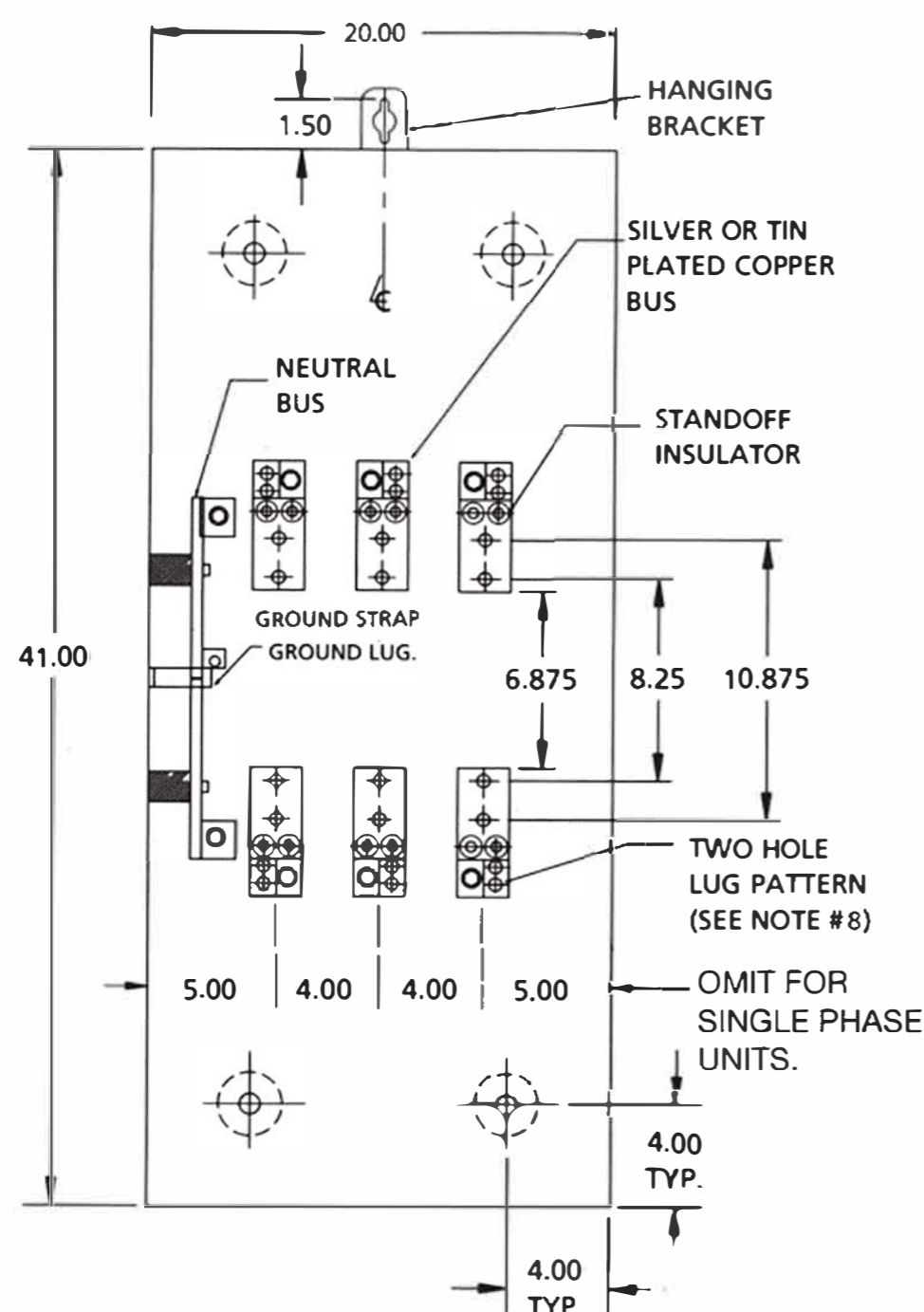
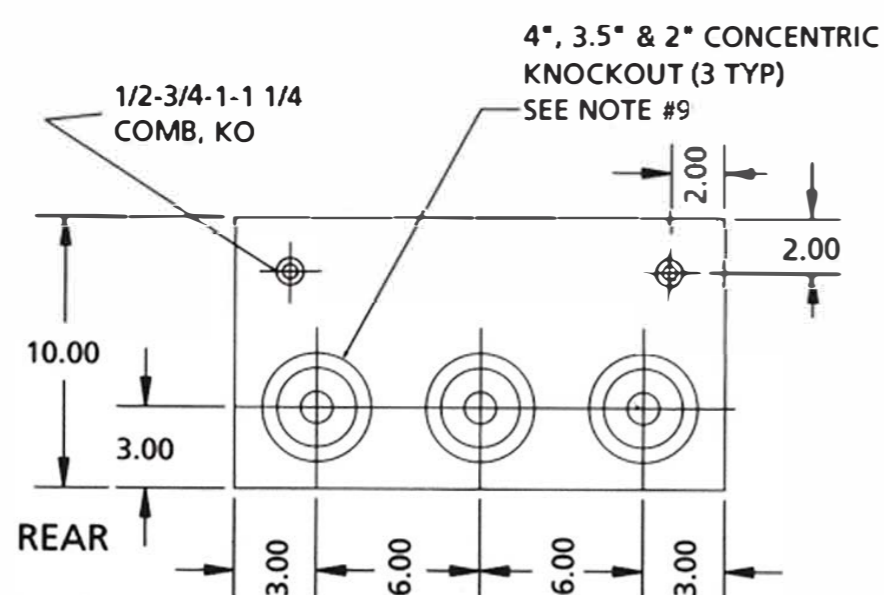

**BOTTOM VIEW**

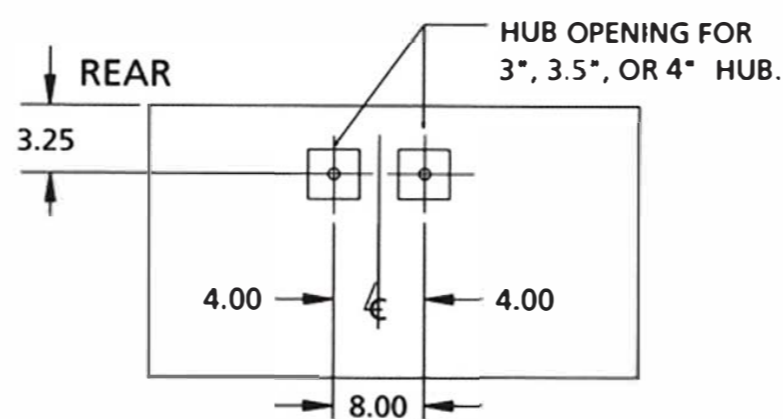

**TOP VIEW**

- CABINET SHALL BE RATED NEMA 3R AND SHALL BE CONSTRUCTED FROM CODE GAUGE GALVANIZED OR GALVANNEALED STEEL.
- BUS BAR SHALL BE SILVER OR TIN PLATED AND SHALL BE SIZED PER THE NEC.
- BUS BAR SHALL BE MOUNTED IN THE CABINET BY MEANS OF STANDOFF INSULATORS OR INSULATED MOUNTING BRACKETS. INSULATING MATERIAL SHALL CONFORM TO THE APPLICABLE SECTIONS OF UL 746 AND UL 94. CABINET SHALL BE UL APPROVED.
- THE RIGHT HAND SIDE OF THE CABINET SHALL ALLOW FOR LINE AND LOAD CABLES TO ENTER AND EXIT THROUGH THEN TOP OR THE BOTTOM OF THE CABINET. THIS SPACE SHALL ALLOW FOR THE CABLES TO MEET THE MINIMUM BENDING RADIUS TO NEAREST PHASE OR NEUTRAL BUS AS PER THE NEC.
- THE SHORT CIRCUIT WITHSTAND CAPABILITY OF THE CABINET ASSEMBLY SHALL BE A MAXIMUM OF 50,000 RMS SYMMETRICAL AMPERES.
- CABINET DESIGN SHALL HAVE PROVISIONS FOR A SOLID DOOR TO ALLOW FOR THE METER ENCLOSURE TO BE MOUNTED REMOTELY FROM THE CABINET.
- MANUFACTURER SHALL FURNISH AND INSTALL \_-13 STUDS WITH SPLIT LOCK WASHERS AND HEX NUTS FOR CT MOUNTING.
- USE ONLY MANUFACTURER'S APPROVED LUG PROVIDED. EACH LUG IS RATED FOR (1) 600MCM-#4 OR (2) 250MCM-#4 CABLES:
- ONLY FACTORY PREFABRICATED KNOCKOUTS ON THE ENCLOSURE SHALL BE USED.**
- PROVIDE PREWIRED TRANS "S" UNIT IN ACCORD WITH LIPA CONSTRUCTION STANDARD: #8908A FOR SINGLE PHASE, 3 WIRE FORM 4S, OR CONSTRUCTION STANDARD #8509A FOR 3 PHASE, 4 WIRE WYE FORM 9S METER SOCKET.

