

2

1

B

B

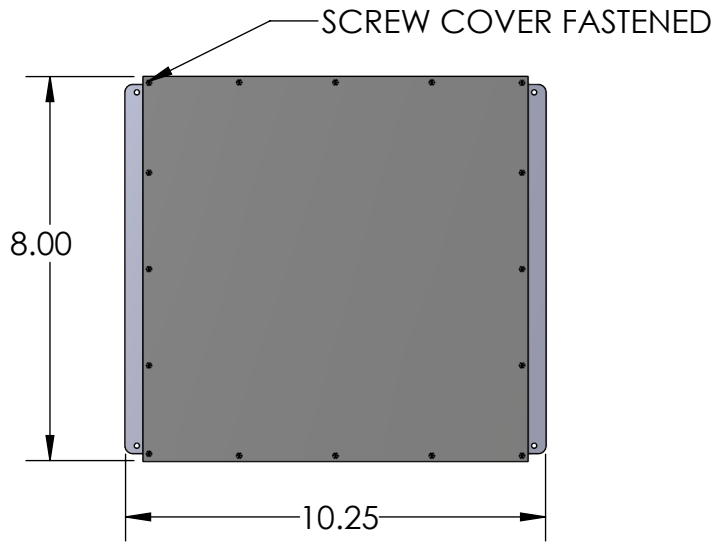

NOTES:

- 1. BOX AND COVER CONSTRUCTION- 304 SS (16GA)
- 2. FINISH: MILL BRUSHED
- 3. CLOSED CELL FOAM GASKETED COVER
- 3. STANDARD 0.75" LIP AROUND PERIMETER OF SC BOX OPENING
- 4. STAINLESS STEEL SCREWS AT CORNERS OF THE BOX AND EVERY 6.00" WHERE SPACE ALLOWS

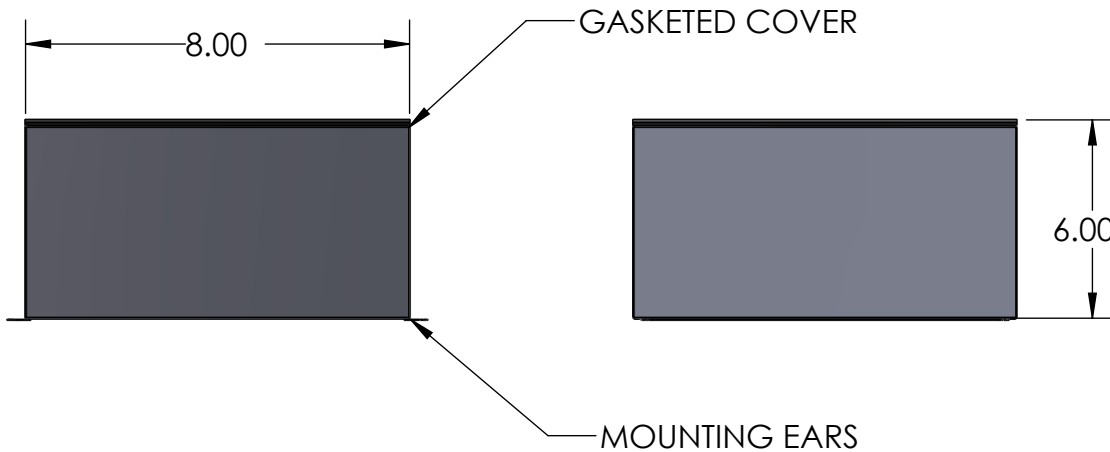
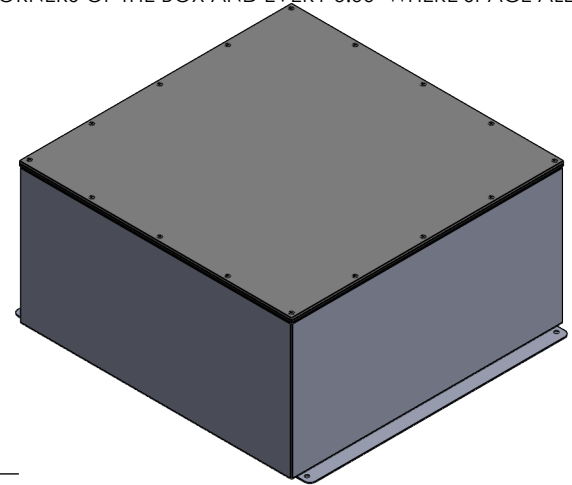

E160783  LISTED
Boxes, Junction & Pull
NAV-TECH INC.
 HAUPPAUGE, NEW YORK

A

A

	NAME	DATE
DRAWN BY	J. Pincus	6/6/2024
APPROVED BY		

PROPRIETARY AND CONFIDENTIAL
 THE INFORMATION CONTAINED IN THIS DRAWING IS THE SOLE PROPERTY OF NAV-TECH INC. ANY REPRODUCTION IN PART OR AS A WHOLE WITHOUT THE WRITTEN PERMISSION OF NAV-TECH INC. IS PROHIBITED.

NAV-TECH
 INCORPORATED

155 MARCUS BLVD
 HAUPPAUGE, NEW YORK 11788
 PH: (718) 257-2111 FAX: (718) 257-2626

MATL:	304 SS
FINISH:	MILL BRUSHED
WEIGHT:	N/A

ALL DIMENSIONS ARE NOMINAL UNLESS EXPLICITLY STATED OTHERWISE

DRAWING TITLE:	WPSC BOX
PART #:	WPSC886-SS

DESCRIPTION:
 WEATHERPROOF SCREW COVER BOX
 NEMA 4X

DO NOT SCALE DRAWING	SCALE	1:35	SIZE	A	SHEET	1 OF 1	REV.	0
-----------------------------	-------	------	------	---	-------	--------	------	---

2

1