

2

1

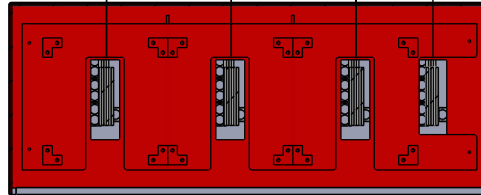
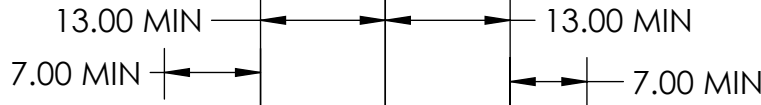
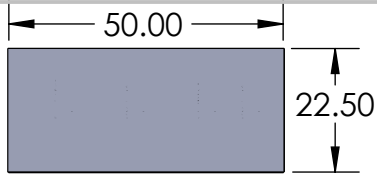

SECTION B-B
SCALE 1 : 20
INSULATED GLASTIC BARRIER

LINE & LOAD SIDES
CLEARLY MARKED

TOP FED STANDARD

BUS HAS 1/4" -20 TAPPED
HOLE IN CT COMPARTMENT
FOR NEUTRAL LUG

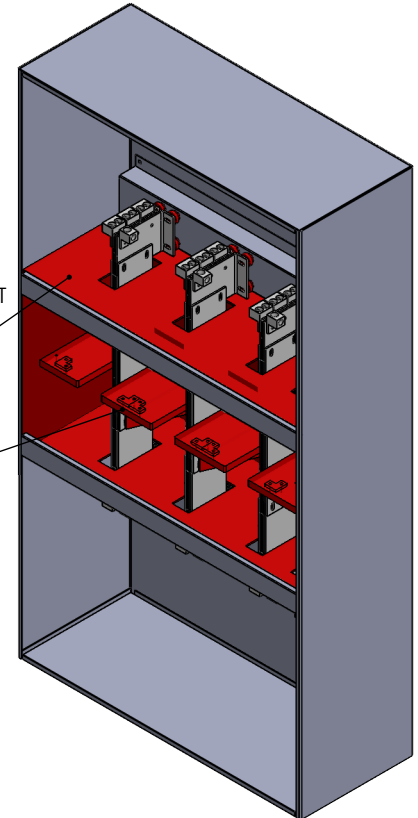

B

NOTES:

1. BOX AND COVER N3R CONSTRUCTION- GALV SHEET STEEL(12GA)
2. FINISH: POWDERCOAT GRAY ENAMEL
3. BUS BARS- COPPER 98% CONDUCTIVITY
4. BOX SHALL HAVE NAME PLATE WITH MANUFACTURER'S NAME
5. FRONT COVERS SHALL BE SEALABLE & LOCKABLE
6. LINE SIDE: PROVISION FOR UP TO (12) 600MCM/ø&±
7. LOADSIDE: MOUNT UP TO (12) 600MCM/ø&±
8. UP TO 2000A: 2 LEAVES OF BUS
9. UP TO 3000A: 3 LEAVES OF BUS
10. UP TO 4000A: 4 LEAVES OF BUS
11. PADMOUNT STANDARD, EXTERNAL WALL MOUNT TABS AVAILABLE UPON REQUEST

B

NEMA 3R SHED ROOF AND SKIRTED
DOORS, COVERS FULLY GASKETED
AND SEAM WELDED CONSTRUCTION

CT STRUCTURAL GLASTIC
MOUNTING SHELF 1" THK

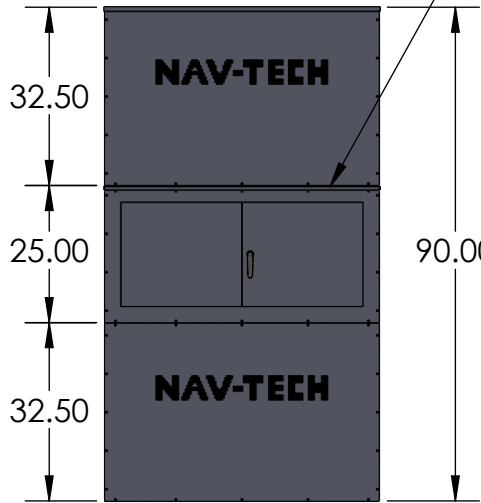

COVERED FRONT VIEW

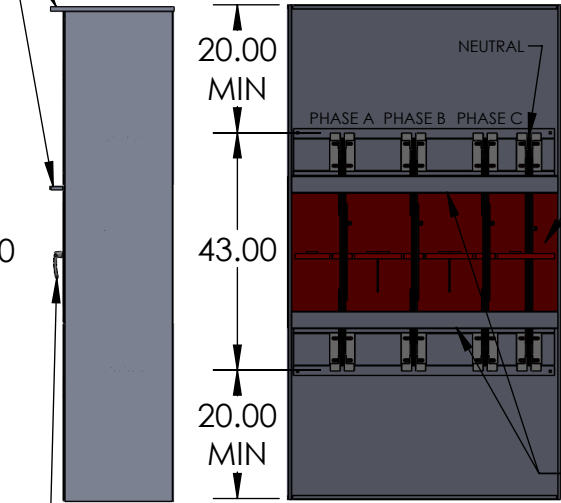

OPEN FRONT VIEW

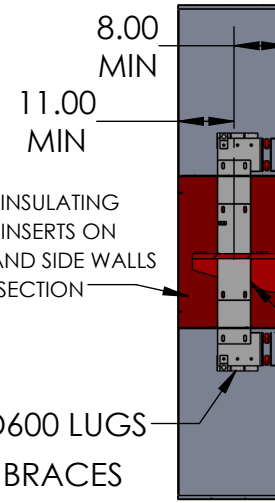

SECTION A-A

UL 891 INSULATING
PANEL INSERTS ON
REAR AND SIDE WALLS
OF CT SECTION

ND600 LUGS

FRONT BRACES

1/4" X 4" CU INTERLEAVED
17.50" CLEARANCE FOR
REMOVABLE LEAVES

QTY OF BUS DETERMINED
BY AMPERAGE DEMAND

A

PADLOCKABLE FRENCH DOOR
WITH 3 PT CATCH

	NAME	DATE
DRAWN BY	J. Pincus	10/7/2024
APPROVED BY		

PROPRIETARY AND CONFIDENTIAL
THE INFORMATION CONTAINED IN THIS
DRAWING IS THE SOLE PROPERTY OF
Nav-Tech Inc. ANY REPRODUCTION IN
PART OR AS A WHOLE WITHOUT THE
WRITTEN PERMISSION OF Nav-Tech Inc.
IS PROHIBITED.



155 MARCUS BLVD
HAUPPAUGE, NEW YORK 11788
PH: (718) 257-2111 FAX: (718) 257-2626

UNLESS OTHERWISE SPECIFIED:
ALL DIMENSIONS ARE NOMINAL UNLESS
EXPLICITLY SPECIFIED OTHERWISE

MATL: 12 GA GALV
FINISH: POWDER COAT ANSI 61 GY
WEIGHT:

UNLESS OTHERWISE SPECIFIED

1. REMOVE ALL BURRS AND BREAK ALL SHARP EDGES .015 X 45° OR .015R
2. DIMENSIONAL LIMITS APPLY AFTER PLATING

3. 125/ MACHINED SURFACES
EXCEPT AS NOTED

DRAWING TITLE: PSEG 377CT N3R SPEC SHEET

PART #: NAV-PG-377CTR-XXXX

DESCRIPTION: NEMA 3R 377 CT CABINET
1600A-4000A 600V MAX
PSEG LI APPROVED WINDOW CT CABINET
BUILT TO PSEG LI SPEC 8802

DO NOT SCALE DRAWING	SCALE: 1:24	SIZE A	SHEET 1 OF 1	REV. 6
-----------------------------	-------------	--------	--------------	--------

2

1

A