

2

1

NOTES:

- 1. BOX AND COVER NEMA 3R CONSTRUCTION - GALV SHEET STEEL (14GA).
- 2. FINISH: POWDER COAT GRAY ENAMEL.
- 3. CABINET WILL HAVE NAME PLATE ON THE OUTSIDE.
- 4. EMBOSSED HOLES IN REAR FOR MOUNTING CABINET.
- 5. GALV STEEL CONFIGURABLE BACKPLATE FOR MOUNTING CT.
- 6. HEAVY DUTY STAINLESS STEEL LIFT OFF HINGES.
- 7. MAX CONDUITS IN & OUT (TOTAL): 4 - 4"
- 8. MAX CONDUCTORS: 2 SETS 600MCM PER PHASE.
- 9. AVAILABLE IN ALUMIUM OR STAINLESS STEEL.
- 10. INCLUDES HARDWARE KIT OF:
 - (6) 3/8"-16 X 1" ZINC SQUARE HEAD BOLT
 - (6) 3/8"-16 ZINC FLAT WASHER
 - (6) 3/8"-16 ZINC HEX NUT

STAINLESS STEEL HANDLE WITH 7/16" HOLE FOR PADLOCK PROVISIONS AND FRENCH DOOR WITH 3 PT CATCH INTERNALLY SHIELDED

TOP VIEW

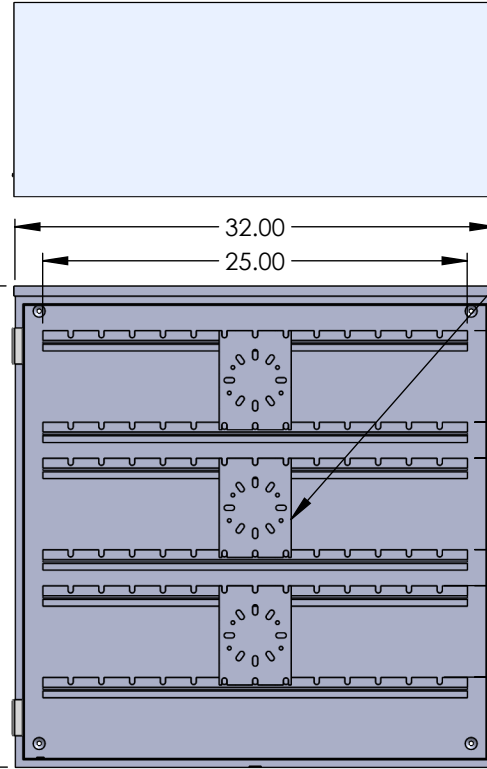

N-150 BONDED GROUNDING LUG

CT MOUNTING PLATE

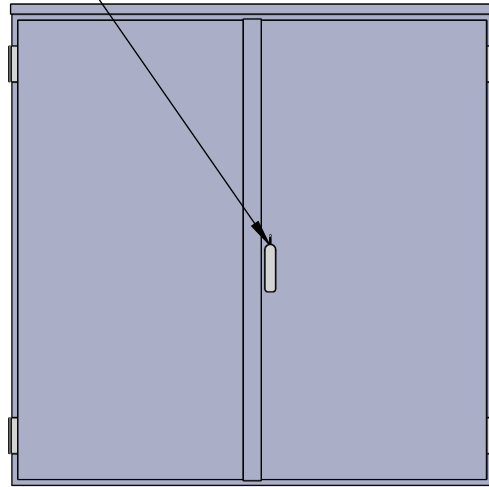
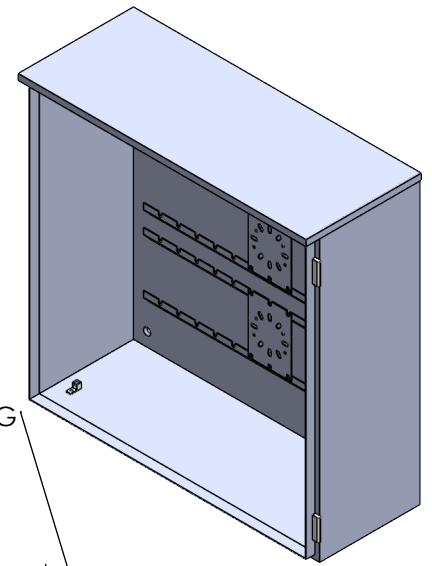
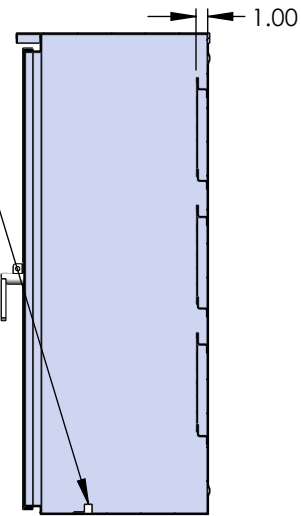
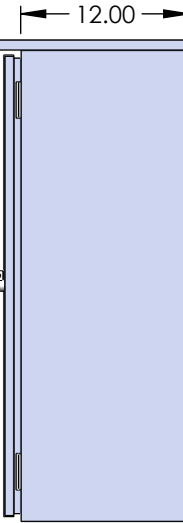

COVERED VIEW

OPENED VIEW

SIDE VIEW

SIDE VIEW SECTIONED

B

B

A

A

NAME	DATE
N. BOSETTI	5/20/2025
DRAWN BY	
REVIEWED BY	



155 MARCUS BLVD
HAUPPAUGE, NEW YORK 11788
PH: (718) 257-2111 FAX: (718) 257-2626

MAT'L:	14 GAUGE GALV STEEL
FINISH:	GRAY POWDER COAT ANSI 61
WEIGHT:	
ALL DIMENSIONS ARE NOMINAL UNLESS EXPLICITLY STATED OTHERWISE	

DRAWING TITLE:	FLORIDA POWER & LIGHT CT CABINET 34 X 32 X 12
PART #:	NAV-FPL-CTR-12
DO NOT SCALE DRAWING	

DESCRIPTION:	FLORIDA POWER & LIGHT NEMA 3R CT CABINET 34" X 32" X 12"				
SCALE:	1:10	SIZE	A	SHEET	1 OF 1
REV.					1

2

1