

CON EDISON "S" PLUG-IN METER SOCKET AND TEST SWITCH
30 AMP. CONT., 208V 240V & 480V AC RATED NEMA 3R

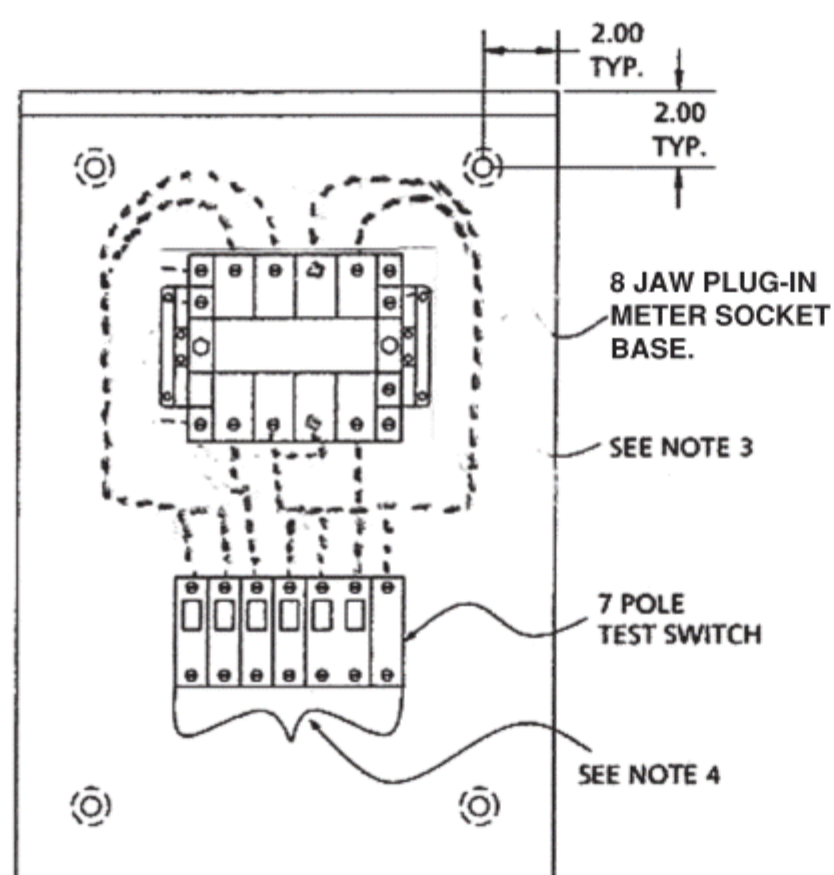

SINGLE PHASE



**FRONT VIEW NO COVER
MS7P-240**

THREE PHASE

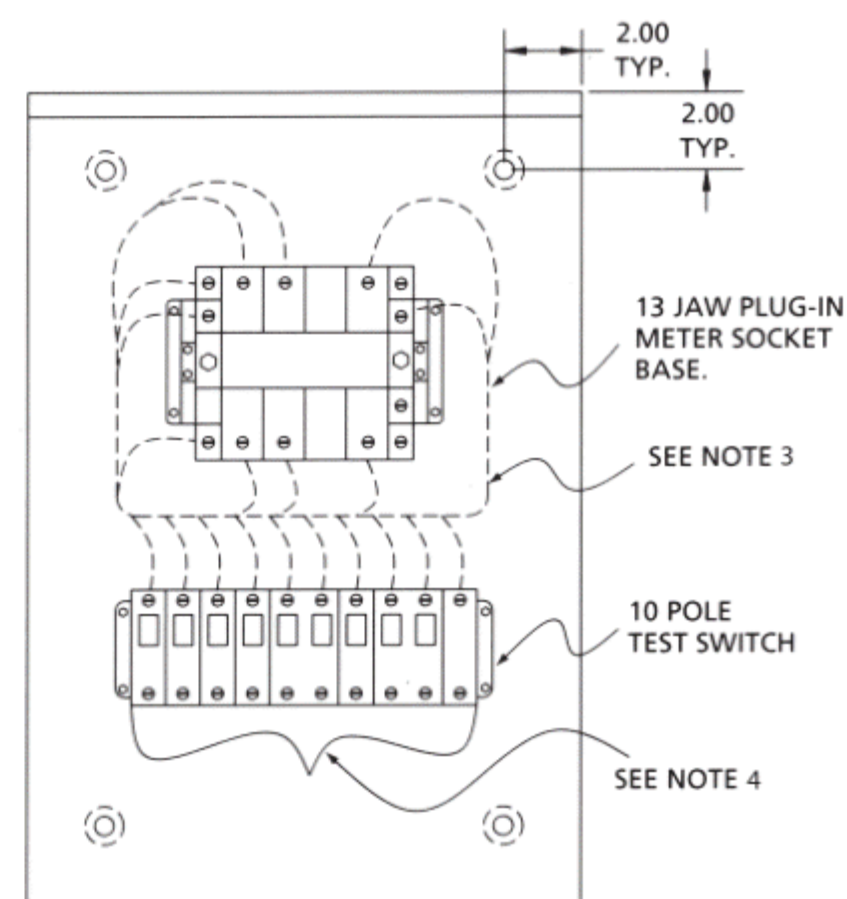

**FRONT VIEW NO COVER
MS10P-208**

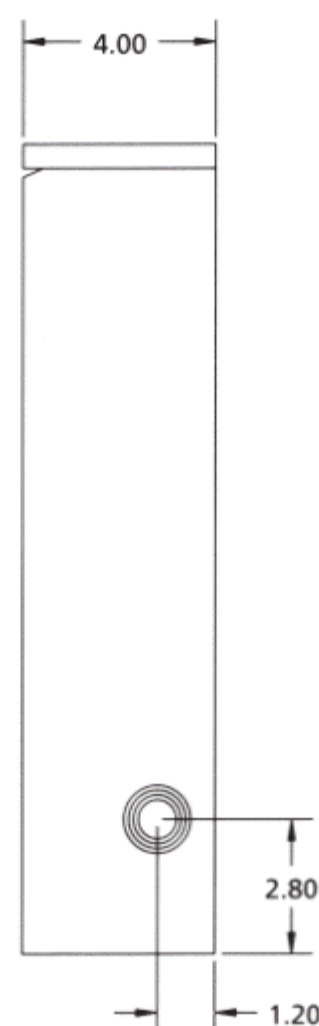

SIDE VIEW

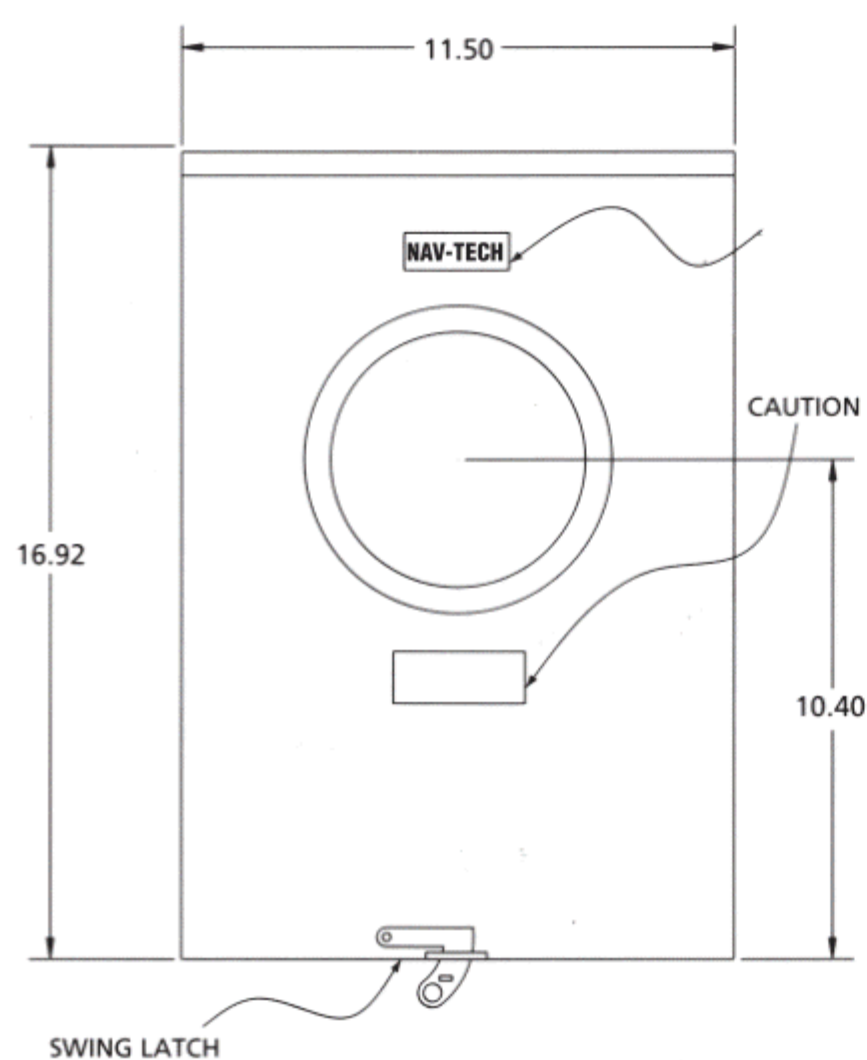

TYPICAL FRONT VIEW

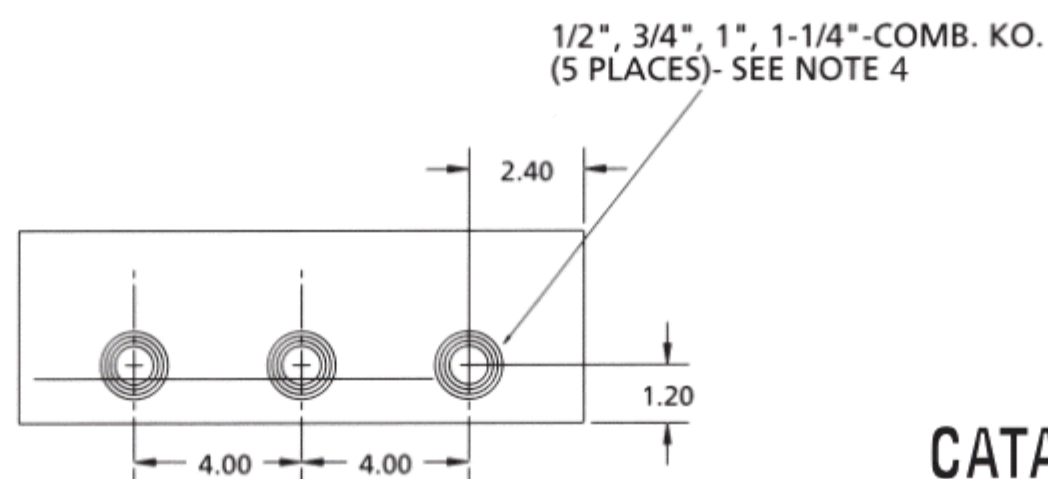

TYPICAL BOTTOM VIEW

CATALOG NUMBERS
MS10P-208
MS10P-480
MS7P-240

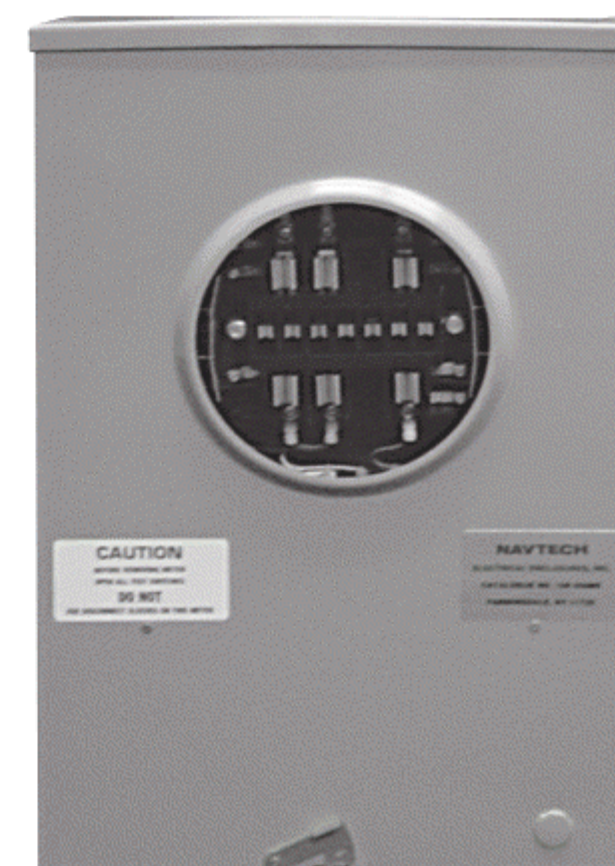

1. CABINET SHALL BE RATED NEMA 3R AND SHALL BE CONSTRUCTED FROM CODE GAUGE GALVANIZED OR GALVANNEALED STEEL.
2. **ONLY FACTORY PREFABRICATED KNOCKOUTS ON THE ENCLOSURE SHALL BE USED.**
3. STANDARD FOR 1 PHASE 3 WIRE FORM METER SOCKET, AND STANDARD 195 CON ED FOR 3 PHASE 4 WIRE WYE FORM 9S METER SOCKET, IS PROVIDED PREWIRED FROM TEST SWITCH TO METER BASE IN ACCORD WITH CON ED CONSTRUCTION.
4. WIRE PROVIDED AND INSTALLED BY CONTRACTOR.

